

2400mm (8') 'F' Shape Barrier NCHRP 350 Test Level 3

VJRICE
CONCRETE
LIMITED

Phone: (902)665-4444
Fax: (902)665-4017
P.O. Box 399, Bridgetown
Nova Scotia, B0S 1C0

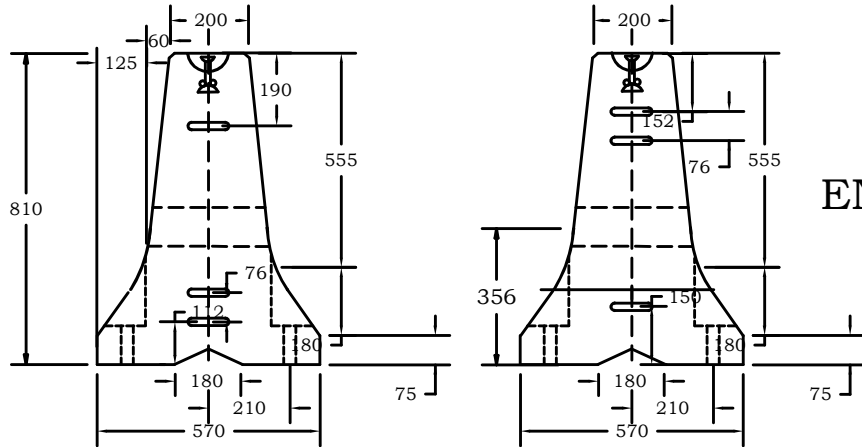

END VIEW

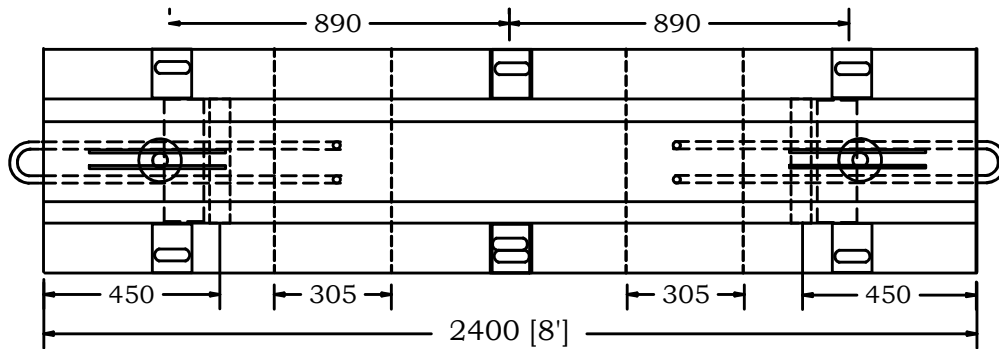

PLAN VIEW

Set With 92mm
Wooden Block

32mm diameter
pin - ASTM A36

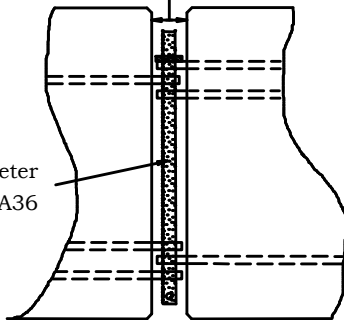

Details Of Barrier Connection

NOTES:

- Concrete strength shall be 40MPa @ 28 days.
- At no time shall the barriers be lifted, moved, etc. by the use of the loop bars at the ends.
- Approx. Weight-1345 kgs
- 50mm (2") Lift Holes & P-52 Lifting Pins

